

# **NAC**

## **NORWEGIAN AFGHANISTAN COMMITTEE**

### **ANNUAL REPORT ON DEVELOPMENT WORK-2006**

Picture 1

## Table of Contents

THE YEAR IN REVIEW .....	2
ABOUT THE NAC.....	4
NAC'S PROGRAMS .....	6
1 PROMOTING A BETTER ENVIRONMENT .....	6
2 PROVISION OF HEALTHCARE.....	10
3 RURAL INFRASTRUCTURE DEVELOPMENT.....	14
4 THE IMPORTANT EDUCATION.....	16
5 GENDER AWARENESS.....	21
DONOR SUPPORT.....	22
ORGANIZATIONAL STRUCTURE AND ADMINISTRATION .....	26
NAC SENIOR STAFF AND BOARD MEMBERS CONTACT INFORMATION.....	27

## The Year in Review

### A Few Highlights

Year 2006 started with the Government of Afghanistan and its international partners meeting in London where they presented and approved the Afghanistan Compact and the Afghanistan National Development Strategy (ANDS). The Compact represents a political agreement between the Government of the Islamic Republic of Afghanistan (Afghanistan) and the International Community. It sets out the framework for the work to be done together for the next five years on bringing progress in the areas of (1) security, (2) governance, rule of law and human rights, and (3) economic and social development. ANDS defines the Government of Afghanistan's strategic development priorities, and reflects the country's commitment to the UN Millennium Development Goals. At that time, the International Community pledged US\$ 10.5 billion for over the next five years (excluding military operations).

The need for these documents and their implementation pressed forward the point that progress on the path to peace, stability and development was not being fulfilled at the rate and extent anticipated in early 2002 at the time of the Bonn Process, and that new impetus was required.

### A Worsening Security Situation

In view of the worsening violence in 2006, namely the rising insurgency in the south and eastern parts of the country, where the Taliban have secured control over larger chunks of territory, of the increase in attacks against Government institutions, officials and members of NGOs, Afghanistan and the International Community concurred that security needed to be addressed as a major concern. The International Security Assistance Force (ISAF), working with Afghan security, expanded its forces to these two regions in July and October 2006 respectively, thus completing its geographical coverage of the entire country. Afghanistan was on top of the agenda at the NATO Riga summit in November 2006, when its political leadership reiterated its sense of responsibility toward Afghanistan and called on the International Community's increased participation. To an important degree, security is a prerequisite for development. Indeed, in the southern provinces of Helmand, Kandahar, Zabul, Uruzgan and Ghazni economic reconstruction has all but halted. Aggravating the situation is poppy growing – which grew by 59% in terms of areas cultivated as compared to 2005 – manufacturing and trade, controlled by warlords. It sustains the insurgency, further undermines security, good governance and development efforts.

## The Civilian Aspects

Corruption, which the drug trade partially finances, and other forms of abuse of power are obstructions to progress and create disillusionment in the democratic process within the population. Improving security and guaranteeing lasting peace cannot be attained solely through military means. Creating an efficient administration, ensuring the rule of law, eliminating human rights violation especially as regards women, increasing the quality of education, improving the population's health, and revitalizing the economy, are only a few of the major issues towards which the Government and its international partners must continue to invest their efforts and funds.

Progress has been achieved: at the end of 2005, the National Assembly, with 27% of seats in the Lower House of Parliament held by women, was inaugurated and has been functioning, several key Government positions were confirmed, humanitarian and development assistance continued to partially cover basic needs and services especially in the health and education sectors, and the economy continued to grow and was valued at US\$ 7.3 billion in 2006 as compared to US\$ 2.4 billion in 2002. However, its effects are not yet sufficiently being felt by the majority of the population. Enormous challenges remain. Because of the devastation caused by more than two decades of brutal war and the remnants such wars leave behind them, Afghanistan, one of the least developed countries in the world, will require many years to attain a level of development that will provide a basic acceptable living standard to its population. As with many contemporary conflicts around the world, peace may be subject to set-backs. These set-backs however must not discourage the people of Afghanistan and its Government nor the International Community in their multi-dimensional engagement in bringing about peace, stability and prosperity to Afghanistan.

## About the NAC

### The Organization

The Norwegian Afghanistan Committee (NAC) is a membership organization which was established shortly after the invasion of Afghanistan by foreign troops in 1979. Local solidarity committees were quickly set up around Norway through which their members generated public opinion against the invasion as well as conducted fund-raising campaigns in order to raise money to assist the growing number of Afghans caught in the middle of the conflict. The NAC opened its first office in Peshawar, Pakistan, in 1983, followed by a field office in Ghazni in 1986, and in Keshem, Badakhshan province, in 1991. In 1997, NAC opened a liaison office in Kabul to provide support to the other offices in Afghanistan. Late in 2002, its Central Field Office was transferred from Peshawar to Kabul. NAC continued to expand its support inside Afghanistan. At one time it had programs in the northeastern, eastern and southeastern parts of the country.

The NAC Head Office is located in Oslo, Norway, where the NAC's Board oversees the work of the Secretary General and carries responsibility for all NAC staff. The Secretary-General coordinates solidarity work ensuring that members actively disseminate information regarding the situation in Afghanistan to the Norwegian public. The Secretary General also carries out fund-raising activities in Norway and oversees the work of the organization in Afghanistan. The NAC's Country Director manages the operations in Afghanistan and ensures in country donations. Strategy is set through a consultative process between the Oslo and Kabul offices.

The NAC is a member of ACBAR, the Agency Coordinating Body for Afghan Relief (ACBAR).

### Its Policy and Strategy

The NAC remains a *non-political, non-religious and non-profit organization*. It is founded on the principle of maintaining a strong solidarity with the Afghan people. Its main goal is to contribute to building a better and stable future for Afghanistan, through programs and projects that directly affect and improve the lives of its people.

The NAC supports Norway's position in promoting not just a continued effort in Afghanistan by the International Community, but an increased "change of pace" – particularly in the civil sphere – as the Norwegian Foreign Minister Jonas Gahr Store expressed in his address to the Storting in October 2006 and again in his commentary of November of the same year in the daily Dagbladet. "The more successful we are in

the civil areas [...], the less we have to depend on military means. Here Norway has an important role to play.”<sup>1</sup>

Indeed, in recent years, the NAC has been implementing programs and projects aimed at improving the quality of life of the people through providing them with a range of basic services and infrastructure in the areas of education, health, rural development and environment. All the programs/projects include a component that supports women. It has been doing so in often remote and/or dangerous areas of the country, reaching those most in need. It has succeeded in maintaining its projects going regardless of the security incidents encountered.

The NAC maintains a required degree of flexibility and has learned to adjust its work in terms of programs and projects it implements, responding to evolving situations. Since 2001 and with the initiation of the democratic process in the country after more than 2 decades of war and bad governance, the NAC, as many other organizations, made a strategic decision to reduce its relief assistance activities and to focus on its long-term development programs. Further, it consolidated its programs in fewer provinces and in specific thematic areas. In 2006, the NAC was fully operational in Ghazni and in Badakhshan provinces. It also continued its project support in Jalalabad city, Nangarhar province.

The NAC responds directly to requests placed to it by local communities and involve the latter in the planning and implementation of projects. Over the years, it has developed close relationships with the communities it serves. The NAC remains an independent organization. As appropriate, and with a view to supporting the Government's positive efforts in rebuilding the country, and supplementing its implementation capacity where it still lacks it, the NAC also works in cooperation with relevant Ministries.

As a measure to ensure sustainability, to build Afghan capacity, and to secure a future smooth handover, the NAC has been staffed entirely by Afghan nationals since 2005, at the exception of one temporary international staff member. Materials used are to the highest possible extent domestically produced and the organization ensures that project implementation is cost effective.

---

<sup>1</sup> Joans Ghar Store, Norwegian Ministry of Foreign Affaires, addressing the Storting in Oct 2006.

## NAC's Programs

### 1 Promoting a Better Environment

#### The need for restoring and protecting the environment

A goal stated in the Preamble of Afghanistan's Constitution is:

"...[to] attain a prosperous life and a sound living environment for all inhabitants of this land..."

Afghanistan will need decades to reach this goal. Indeed, the combined pressures of over 25 years of armed conflict, land overexploitation, large scale illegal logging for commercial purposes, lack of good governance, and drought have significantly degraded Afghanistan's environment, with a huge decrease in the natural resource base. Environmental depletion and scarcity of natural resources do not only make the already deprived poorer, they hinder economic growth, while they are also often a cause of political instability and war.

Consequently and in line with Afghanistan's Constitution, Afghanistan incorporated the environment as an integral part of the country's rehabilitation and reconstruction policies and strategies, realizing that a healthy environment is a prerequisite for achieving sustainable rural development. In April 2005, the National Environmental Protection Agency (NEPA) was established. In December 2005, the Environmental Act was promulgated by presidential decree. Parliament reviewed the Act and adopted its final version, the Environmental Law, during 2006. It was published in the Official Gazette in January 2007. Environment was included in ANDS as a cross-cutting theme, engaging all relevant line ministries to integrate environmental considerations in development projects.

#### NAC's Contribution: an Integrated Reforestation Program

Witnessing the degradation of the environment and its negative effects on local communities, the NAC has formulated and, since 1997, in Badakhshan, has been implementing an Environmental Program, focused on restoring deforested and degraded forest landscapes. Indeed, as a result of often illegal timber cutting for commercial purposes as well as households needs, combined with a lack of alternative energy sources for domestic use, and other factors, Afghanistan's forests have been cut in half since 1978. Targeting local communities, the Program combines practical teaching and extensive physical demonstrations of various social forestry techniques and forestry protection methods. The NAC has been setting examples replicated by local communities and individuals. By doing so, the NAC is ensuring sustainability of the Program. The main aspects of the Program are described below.

## I. Social Forestry

The NAC established a Central Nursery & Demonstration Farm in Keshem in 1997. Today this Farm, situated on the bank of the Keshem river, covers an area of 12 hectares. Over the years, nursing farms have been established in Tagab-e-Keshem, Shuhada, Faizabad, and, in 2006, in Jari-e-Sahah Baba. The nurseries produce a large number of saplings used for implementing NAC's other Environmental projects. Namely, the nurseries provide saplings that are transplanted on degraded forest areas, on watersheds, in public areas, and on private properties. Other seedlings/saplings are sold on the local market, which very modest income is channeled back into project funds. Besides providing saplings of fruit and non-fruit species, the Farms also demonstrates cultivation techniques, greenhouse and flower management. A spin-off has been the setting-up 30 private nurseries with NAC's technical assistance. These private farms contribute to reforestation, while the owners generate income from the sale of saplings to private orchards.

### **A few figures on saplings planting:**

During 2006, 9150 different kind of sapling trees grown on NAC farms have been planted within the area: 2025 in schools, 1700 on road sides, 445 in NAC's Women Garden in Faizabad, 240 on Faizabad's TV hill, 200 at the Keshem health clinic, 170 on the compound of the provincial Ministry of Interior in Faizabad; 2703 in Tagab-e-Keshem and 1835 in the Jari-e-Sahah Baba NAC nurseries respectively.

In addition and most notably, since the end of 2005, when the Faizabad Demonstration and Nursery Farm was established on bare and stony land, 12,410 fruity and non-fruity trees have been planted on it, transplanted from NAC's Keshem Farm. The Faizabad Farm has grown to cover 11 hectares. Further, 15,867 poplar cuttings were planted in Keshem district.

Picture 2

*Laborers preparing the Dasht-I-Qurogh nursery, Badakhshan*

## II. Watershed Management

Landslides, soil erosion and degraded slopes are common problems in Badakhshan that threaten and may destroy the arable land, the homes and the lives of its inhabitants. In order to ameliorate the situation as well as to prevent further degradation, the NAC runs a Watershed Management project. In 2006, 18,000 meters of terraces have been constructed on 10 hectares of sloppy hills in Keshem, where they extend the existing terraced lands, and Faizabad districts respectively. The entire area has been covered with 8,300 non-fruit and fruit-trees from the NAC's Central Nursery and Demonstration Farm in Keshem as follows: 4000 various types of saplings in Chashma Garmuk, 3,700 in Keshem which extended the previous watershed, 350 in Wakhshi; 250 pine saplings in Nayaba, 200 pine saplings in Takia. A watershed project is usually initiated based on a request by a local community and approved by the Provincial Agricultural Department. Any produce obtained is administered by the local community.

### **III. Forest Protection**

In order to prevent illegal cutting of forests as well as encroachment on pasture and range land, the NAC set-up a small 3 person-on-horseback Forest Protection patrol. In addition, with a view to ensuring community participation and responsibility, it trained 100 community members in Forest Protection. During 2006, incidences of illegal forest cutting have continued to decrease. Fines have been imposed on violators. The proceeds are administered by local communities, and are channeled toward community social needs. Forest Protection Officers also impart knowledge on plant diseases, sound agricultural practices, among which contingency planning in cases of drought and other adversities, and on animal health.

### **IV. “Foster-Mum” Project and “Food for Work”**

The “Foster Mum” project is a 100% women-based environmental project. Due to cultural constraints most Afghan women encounter enormous obstacles when trying to make a living for themselves and their children. As a consequence many are living in extreme poverty. In order to improve the lives for a number of widows, while at the same time promoting environmental practices, in 2006, the NAC hired 100 widows to act as “Foster Mums” and nurse 500 seedlings each. After a year, the plants are returned to the NAC Nursery and Demonstration Farms for another year, and subsequently transferred to the NAC’s public reforestation projects or private gardens for permanent plantation. In addition to nursing the seedlings, the “Foster Mums” met each other about once a month in order to exchange experience on seedling nursing, as well as to discuss other matters of concern to them, thus the project is enhanced by a social component.

NAC’s Environment Program also provides short-term “Food for Work” employment to several hundred of the poorest members of local communities, providing them basic food staples to feed their families (400.9 metric tons was disbursed in the reporting year). This in turn allows some of their children to attend school instead of grappling to earn a pittance doing odd-jobs or begging.

Picture 3

Foster Mums receiving training at NAC’s Keshem nursery

### **V. Environmental Awareness**

In order to increase the understanding of the need and the benefits of improving and preserving the environment and of the types of environmental degradation, their causes and effects, the NAC holds awareness workshops. In 2006, NAC Environment Program staff ran a 1 week workshop to which staff and 500 children from 2 schools in Keshem and 2 schools in Shuhada participated. The workshops included field visits to NAC

demonstration farms where the participants learned about technical forestry management. In addition, saplings were distributed to these schools for planting and further tending by the students.

Picture 4

*Environmental Awareness Workshop in Girls' School, Badakhshan*

NAC's Environmental Program is regularly visited by various international and national interested organizations, institutions and other parties. It has offered an example that has inspired others.

## 2 Provision of Healthcare

### Current status of health in Afghanistan

Especially over the past couple of years, there have been noticeable improvements in Afghanistan's health status. Afghanistan's National Health Policy combined systematic cooperation with NGOs, designed standard Basic Packages of Health Services (BPHS) implemented throughout the country, ensured external monitoring and evaluation, called upon local consultants and established geographical implementation clusters, which accounts for the reasons of success. Some health indicators illustrate the progress: infant mortality has dropped 18% since 2001 when it was at 165/1000 births as compared to 135/1000 birth in 2006; the number of women receiving pre-natal care increased from 5% in 2003 to 63% in 2006; major vaccinations coverage rose from 35% in 2000 to 85% in 2006. Even in Helmand province where violence has been on-going and despite the assassination of 4 public health workers and the destruction of 15% of health centers, the number of patients rose from 157,000 in 2004 to 338,000 in 2006. In 2001, 8% of the population had access to health care while in 2006, basic health services were available to 80% of the population. The index for quality care measuring patient satisfaction, provider knowledge, quality patient-provider interaction, and utilization by the poor also increased by 35% (sources for the above: John Hopkins University, World Bank, WHO , others).

However, the health status in Afghanistan was among the poorest in the world even before the country was engulfed in 25 years of armed conflict. Therefore, despite these successes and the continuous efforts of the Ministry of Public Health (MoPH), the international aid community and NGOs, Afghanistan's health indicators remain some of the worst in the world. Among factors contributing to this low status other than health care delivery, are food insecurity and lack of clean water supply. Further, significantly increased high poppy and opium production has led to a growing number of intravenous drug users (IDUs), which in turn increases the occurrences of blood born diseases like hepatitis B, hepatitis C and HIV/AIDS. Decades of conflict and increase in IDUs have put disability, HIV/AIDS, and mental health in the row of emerging priority health problems.

These factors continue to slow down the speed of health improvement. It reduces productivity, causes loss of working hours, especially that of poor people, weighs on household budgets and thus aggravates the poverty situation in the country.

### NAC's contribution

Realizing the importance of health services in any emergency and conflict situation, NAC started providing mobile emergency health assistance to the people of Afghanistan

as of 1986. After 1992, the NAC set up a network of clinics in the eastern part of Afghanistan, as well as in Paktia and Ghazni provinces, and in Kabul. The NAC has also been supporting education of female doctors, nurses and midwives. The latter is crucial to meet women's poor health indicators. It also provides job alternatives for women.

## **I BPHS**

In 2005, the NAC was awarded a bid for the implementation of a BPHS by the MoPH. The NAC was allotted 3 geographical "clusters" in Ghazni province, covering about half the province, among which remote rural areas. It chose as its implementing partners two Afghan NGOs, HEWAD and UMCA. In accordance with the MoPH's policy, it had to close down or hand over its health projects in Nangarhar, Laghman, Kunar, Nooristan, Paktia and Kabul to other MoPH implementing partners.

During 2006, the NAC, with its implementing partners, continued implementing the BPHS in Ghazni. However, the security situation deteriorated in southern part of the country, among which Ghazni province. This disrupted delivery of services in some parts of Ghazni covered by the NAC. In the worst cases, health facilities were closed down for several months before reopening while other health services were transferred to different locations. Despite staff being the target of violence and threats, the NAC and its implementing partners coped with the situation, in part due to the good relationship with community elders and health committees.

In May 2006, NAC's contract with MoPH was renewed under the same conditions until May 2008. Under this contract, health services are provided through 2 district hospitals (DH), 9 Basic Health Centres (BHC), 9 Comprehensive Health Centres (CHC) and 177 Community Health Posts (CHP) staffed with 177 male and 118 female Community Health Workers. A total of 345,000 people have access to the services in the seven districts covered by the NAC and its 2 local partners.

### Picture 5

A BPHS includes in- and outpatients services for the treatment of common disease, selective and emergency surgical procedures, and treatment of tuberculosis through the DOTS method. In addition, it provides immunization against preventable diseases, maternal care, family planning, and emergency obstetrics care, as well as health education and awareness programs.

In 2006, a total of 215,762 patients were treated for a vast range of illnesses in the health facilities of NAC run by

### Picture 6

*Male nurse at Maqur CHC Administrating oxygen to patient*

228 health workers and managers. Out of this number almost 50 % were women. In the 2 district hospitals, 354 minor and major surgeries were conducted. All these surgeries were carried out with no mortality or morbidity. The worsening security situation badly affected the mobility of *Doctor examining patient at Maqur CHC*  
Extended Program on Immunization (EPI) outreach teams which prevented reaching the 100% target. The average percentage of EPI in children under one year of age was: BCG 99 %, OPV3 73 %, DPT3 66% and Measles 71%.

Picture 7

*Female doctor examining child at Maqur CHC*

## II. Mother and Child Health Clinic

In addition to implementing the BPHS, the NAC also contributes to the MoPH's efforts to improve the health of women and children by supporting the HEWAD Mother and Child Health (MCH) clinic in Jalalabad city. As its name indicates, the clinic provides health care services only to women and children. Its entire medical and support staff is female. The clinic is servicing adjacent districts and a neighborhood inhabited by displaced persons and the poor. The clinic is therefore easy of access and caters to the most deprived women, among which widows and women headed households.

The out-patient HEWAD MCH clinic provides the following services: obstetrics/gynaecology, oral re-hydration, dental care, health education. It is equipped with a laboratory and a pharmacy.

During 2006, 15,934 women sought antenatal, natal and postnatal care. Many others benefited from the other services provided by the clinic. A total of 7,804 children of age under five were brought to the clinic where they were treated for illnesses such as diarrhoea/dehydration, acute respiratory infection (ARI), ear/nose/throat infections, general skin problems, minor wounds.

Picture 8

*Delivery room and Midwife at the Mother and Child Health Clinic in Jalalabad*

The clinic set up a Women's Health Committee. The Committee comprises 18 members of which 4 are staff of the clinic, the remainder are respected women from the surrounding communities. All work on a volunteer basis. The Committee has 2 main activities: 1) dispensing health education to women in the community through group home visits and 2) acting as liaison between patients, often illiterate, and the clinic.

In 2006, a total of 42,143 women attended health education sessions, both within the clinic providing by Community Health Educators, and through home visits provided by the Committee members.

### **III. Midwifery Training Program**

The NAC is equally keen in building the capacity of Afghan health professional, as it is in providing health services.

The NAC offered its HEWAD and UMCA partners as well as its own staff various in-country refresher training courses on tuberculosis detection and treatment, mental health, and on planning for development in the health sector.

Picture 9

#### ***Women in first year of hospital mid-wife training at the IHS in Jalalabad***

More so, in view of the shortage of qualified female health staff, and of the high incidence of women related illnesses, combined with the cultural constraints preventing women to be treated by male health staff, the training of women in the health sector assumes significance. The NAC has been training female health workers since 2002. Taking into consideration that the assistance of skilled mid-wives during delivery is critical to reducing maternal and peri-natal mortality, and that only about 15% of birth deliveries are attended by skilled health care workers, in 2006, the NAC focused on supporting hospital mid-wife training. The training is part of the Institute of Health Sciences' (IHS) wider midwife training program in Jalalabad city, Nangahar province. During 2006, 54 students graduated, while 21 were in training. In addition to midwifery training, the students are offered English language and computer course. The set-up is such that students residing in areas other than Jalalabad are accommodated at the IHS during the present 2 year training. Upon completion of the training, they are assisted in finding jobs in their home towns and villages. NAC has to a great extent handed over responsibility for implementation to the IHS, while it finances the operations. Today, thanks to these efforts and that of other NGOs, in Nangahar, 90% of health facilities employ trained and certified midwives.

## 3 Rural Infrastructure Development

### Community Water Supply

Improving the country's health status does not only depend on the provision of universal health care services. "We shall not finally defeat AIDS, tuberculosis, malaria, or any of the other infectious diseases that plague the developing world until we have also won the battle for safe drinking water, sanitation and basic health care"<sup>2</sup>. With these words, the "2005-2010 International Decade for Action-Water for Life" was opened on the World Day for Water on 22 March 2005, pushing forward the point that access to clean water is a basic Human Right.

Clean water is essential for drinking, cooking and cleaning. It is also vital for animal consumption in a country where about 70% of the population remains rural, and where livestock is a source of food, wool, leather and therefore livelihoods. Many mountainous rural communities depend on mountain springs. The water from these springs flows into a ditch dug by the communities. The water from the ditch is then used for both human and livestock consumption, contaminating the water. Alternatively, villagers, especially women and children, walk hours to reach clean springs, which keeps women away from more productive work and girls out of schools. Floods are another cause of unclean water. The result is a high level of serious waterborne diseases, such as diarrhoeal diseases, typhoid, dysentery, cholera, schistosomiasis, skin infection, eye infection, and ringworm. Waterborne diseases are among the leading causes of mortality in developing countries. Easy access to clean water is therefore essential to sustain life and human development.

### NAC's contribution

#### Picture 10

*Clean Water Reservoir, Qatar Beed Community, Ragh District, Badakhshan*

The needs for clean water in Afghanistan remain immense. In 2006, 23% of the population had access to clean water, and this percentage is significantly lower in rural areas (source: MoPH/UNICEF). Since 1996, the NAC has constructed some 70 clean water reservoirs, most of which in Badakhshan province. The NAC builds closed water reservoirs. The water is collected through underground pipes, and is dispensed through taps. This type of reservoir ensures the cleanliness of the water and its availability year round. Water not collected by people is separately channeled for animal consumption. Because the need for clean water in Badakhshan remains very high, the NAC continues

---

<sup>2</sup> Kofi Annan, former Secretary General of the UN, on World Day for Water, March 2005.

to focus its construction of clean water source supplies in that province. In 2006, the NAC completed the construction of 3 clean water supply reservoirs: 1 in Yaftal district, 1 Kohistan district and 1 in the remote mountainous village of Qatar in Yawan district (all formerly Ragh district). They have made easy access to clean water available to respectively 1130 families or 7910 persons, and to 9250 domestic animals.

## 4 The Important Education

### Achievements and remaining shortfalls

Education is the second most important priority set in the United Nations Millennium Development Goals (MDGs). Way before it presented its MDGs Report in 2005, Afghanistan was fully aware that education is a major factor in ensuring a country's development. This is clearly reflected in the fact that, ever since 2003, Afghanistan has allotted the second largest budget, after security, to education.

Literacy rates were extremely low, below 30% according to some estimates, before 1978. Since 2002, with a changed political environment and the "Back to School" campaign, Afghanistan has made huge leaps forward as regards providing education to its children. It is estimated that school enrollment doubled and that 5.1 million children are attending school, more than ever before in Afghan history. During 2006, the Ministry of Education (MoE) in collaboration with several partners, developed the LAND (please see paragraph "Literacy and Vocational Training") and a new Secondary Curriculum Framework. It has also been working on the five-year Strategic Plan for Education which should be finalized in 2007. With a view to reducing illiteracy by 50% by year 2010, it continues to participate in the UN Literacy Initiative for Empowerment (LIFE) a goal of the UN Literacy Decade 2003-2012.

However, some 45% of Afghanistan's children are still not going to school, the drop out rate is high, and girls still represent only 29,50 % of school enrollment. The literacy rate among the over 15 year olds is as low as 43 % (source: UNICEF). And, most unfortunately, during 2006 education has been a target of the increased insurgency, especially, but not exclusively, in the south and southeastern parts of the country. Indeed, schools, particularly girls' schools, have been destroyed or attacked by various groups, while pupils and teachers have been threatened. This resulted in the closure of many schools, leaving between 100,000 to 200,000 thousand pupils out of school. As of September 2006, more than 40 teachers, students and schools employees have been killed (source: UNHCR Sept 2006). The number of school related incidents (burnings, explosions, missiles, threats) sextupled in the first 6 ½ months of 2006 as compared to the same period in 2005 (source: UNICEF). Taking into consideration that Afghanistan's educational system remains weak, the violence directed at it and its beneficiaries has slowed down improvement in this domain.

### NAC's Contribution

The NAC has been providing assistance to the education of Afghan children since 1983 when it started supporting education for Afghan refugee children in Pakistan. Since 1986, it moved the bulk of its operations to Afghanistan. During 2006, it has continued

its activities in the areas of Teacher Training, school support in terms of provision of materials, literacy and vocational training, and school construction. These are discussed in greater detail below.

## **I. Teacher Training Program**

For years the Afghan education sector has had a critical shortage of teachers, both in terms of actual numbers as well as in terms of quality. This problem is even more acute in remote areas where the majority of teachers are under-qualified. This refers to both knowledge of subjects taught and pedagogical teaching methods. In 2003, it was estimated that 22% of teachers were education college graduates, while the majority of the others had not completed high-school. The upshot is low quality education. To address the issue of 140,000 under-qualified schoolteachers, in 2004, the MoE established the Teacher Education Program (hereafter: TEP). The ANDS elaborated in 2006, set 2010 as the benchmark for "...70% Afghan teachers will have passed a competency test...".

Picture 11

*Teacher Trainers in Faizabad, Badakhshan*

Low standard and ineffectual education is one of the factors that discourages parents from sending their children to school. By improving the quality of the education, Teacher Training contributes to children staying and completing middle school, as required by law. It also increases the chances of them moving on to high school and university. In addition, education generates awareness on issues related to health, the environment, poverty reduction, and basic citizens' rights and obligations, which in turn contributes to ameliorating the general standard of living of a community. Quality education will create a population capable of making an impact on the development of their country.

Through its Teacher Training project, the NAC contributes to the above goals. In 2006, in Badakhshan, the NAC trained 500 teachers (327 male and 173 females) from 155 schools attended by 15000 children (9000 boys and 6000 girls); in Ghazni 243 teachers (150 males and 93 females) from 23 schools attended by 13648 children (9583 boys and 4065 girls) were trained. Teachers grades 1-12 were taught teaching methodology according to the MoE TEP Inset I manuals. In addition, high school teachers were given supplementary teaching in Social Sciences and General Sciences.

Picture 12

*Teachers participating in a Teacher Training course, Ghazni city*

## II. Support to schools

In Badakhshan, during 2006, the NAC provided stationary supplies to 121 schools in 11 districts and administrative books to 232 schools. It also furnished 12 schools with libraries, and 6 schools with school furniture. A total of 50,289 students (26,906 boys and 23,383 girls) benefited from this material and equipment. In Ghazni, the NAC provided similar support: libraries were provided to 19 high and secondary school, administrative stationary was distributed to 60 schools, and school furniture to 37 schools. In addition, the Provincial Education Department was also given supplies of stationary, examination sheets and attendance books. Similar support has also been provided to two schools in Peshawar, Pakistan benefiting 936 refugee children, the majority of which are girls.

## III. School construction

Proper education cannot be dispensed without adequate physical school infrastructure. Afghanistan's school infrastructure, not well developed before 1979, was extensively affected during 25 years of war and bad governance. School buildings were left to disintegrate, were damaged in the fighting or, as of 1994, in the case of girls' schools were purposefully destroyed. The situation today is as follows: though 3,500 schools have been built in recent years, 40% of formally registered public schools are without buildings according to the MoE, in which cases classes are held in the open air, under tents, in high-rental community or privately owned buildings, or in mosques; many existing school buildings are dilapidated; others are too small to accommodate the larger amount of students now attending school. The MoE informs that 3500 schools have been in recent years, but that 40% of schools remain without buildings.

### Picture 13

*Alberony boys' school, Jarmtu District, Ghazni Province*

The NAC has been building schools in Afghanistan since 1992. It uses its expertise to respond to the requests to build schools submitted to it by local communities, a clear indication that parents are eager for their children to get an education, which requests are also channeled to the NAC through the various levels of the Ministry of Education. Appropriate school infrastructure increases school enrollment and attendance, especially that of girls. The beneficiaries are mostly children of poor farmers who in most cases are illiterate. With access to schools, and knowledge gained through education, these children are given an improved opportunity for employment in the future. In 2006, the NAC built schools in various districts of Ghazni province. The NAC carried on its work, regardless of the worsening security situation. One school in each of the following districts was built: Qarabagh for 400 boys, Waghiz for 500 boys, Andar for 470 boys and Jarmtu for 850 boys. In addition, the NAC built a security wall around a large 3500 girls' school in Ghazni city. Such walls are particularly important for the school to be accepted as suitable for girls.

A bi-product of construction projects is the job opportunities they create for the very poor local skilled and unskilled laborers.

#### **IV. Education for Women: Literacy and Vocational Training**

##### **The Afghan Constitution**

Provisions that guarantee equal rights of women are found in earlier and the present Afghan Constitution as well as in several international conventions of which Afghanistan is a signatory. However, the implementation of these provisions has been irregular and very incomplete due to a combination of social, cultural, economic and political conditions, as well as the state of war. In 2002, the Ministry of Women's Affairs' was established. Article 22 of the 2004 Constitution confirms equality between men and women, while Article 44 stresses the need to improve women's education. NAC's Literacy and Vocational Training (L&VT) project specifically contributes to the MoE's National Education Program Five Year Strategy 2006-2010, especially its Technical/Vocational Education, and its Literacy and Non Formal Education programs.

##### **NAC's Contribution**

NAC's project aims at reducing the level of poverty and improve the living standards of impoverished women and their families, by providing them with marketable skills, and at decreasing the degree of women's dependency in all aspects of life, by also imparting reading and writing capabilities. In turn, women's capacity to better understand and participate in the development of their local communities increases, and it does so in a wider range of roles than that of a wife/housewife/mother. Consequently, women's status in society improves. As a corollary, mothers of children who are obliged to work to provide for their families will do so instead, allowing their children to go to school, which will in turn increase the latter's opportunities for earning a living in the future.

In 2006, the NAC established one Literacy and Vocational Training Center in Badakhshan and in Ghazni respectively, providing training to a total of 60 beneficiaries. The beneficiaries are selected according to set criteria aimed at ensuring that among the most vulnerable women in the community will benefit from the training. Women were taught literacy through the MoE National Literacy Textbook, part of the Literacy and Non-formal Education Development in Afghanistan (LAND AFGHAN). It provides them with the equivalent of three years of primary education. They also learned a wide range of sewing skills. Upon completion of the 9 months course, the trainees were awarded a certificate and given a complete sewing set. In 2007, they will be further assisted by a Marketing Officer in learning marketing and business skills in order to improve their opportunities for income generating.

Picture 14

*Literacy and Vocational Training (sewing), Ghazni city*

## **V. Capacity Building**

As already discussed above, years of war and bad governance stunted educational development. Educational deficits touch not only on quantity, but also on quality. As a contribution to enhancing the professional knowledge and skills of Afghan professionals, the NAC has been keen on providing its staff, that of its partners and other associates within government with capacity building opportunities. During 2006, about half of its health staff participated in various types of health related trainings. Its administrative, finance and managerial level staff received training in management and/or financial management inside and outside the country. NAC staff as well as several members of the provincial MoE offices sponsored by the NAC, took part in educational management and course development workshops, while Teacher Trainers underwent a separate specialized course. English and computer training was also offered to several staff members. Most of the courses took place in Afghanistan and were provided by Afghan and/or foreign experts, while others were held in neighboring countries.

## 5 Gender Awareness

When elaborating its programs and projects, the NAC has continuously ensured that particular attention be given to integrate a women's component. This is concretely reflected in the "Foster Mums" and the L&VT projects whose direct beneficiaries are exclusively women. The L&VT project also created 10 new jobs for females only. Projects aimed at continuous education of women such as the midwife training and teacher training for females are further activities that contribute to the empowerment of women.

As part of its efforts to contribute to the advancement of women, in January 2006, the NAC hired its first female Line Manager, in the field of Education. The NAC is keen on hiring more women at different levels. However, considering that the majority of Afghan women traditionally does not work outside of their homes/lands and/or are not sufficiently qualified, reaching parity in this regard is a long term endeavor.

In 2006, the NAC engaged in raising gender awareness through a set of workshops. Three-day workshops were held for NAC staff from its Central and Regional Office. Workshops were also organized for approximately 150 NGO partner staff in Ghazni, 70 L&VTC staff and beneficiaries in Ghazni and Badakhshan, and 60 school teachers in Badakhshan. In addition, in the same province, 470 school-boys for the first time were acquainted with the subject. In cooperation with the MoWA and other NGOs, the NAC organized a workshop in Kabul on the meaning of and options for translating into Dari and Pashto the concept of "gender".

## Donor Support

During 2006, the NAC continued with its long-term development activities within the sectors of health, environment, education and infrastructure construction in the provinces of Badakhshan, Ghazni and Nangarhar with support from the Norwegian Royal Ministry of Foreign Affairs (MFA), the Norwegian Agency for Development Cooperation (NORAD), FOKUS, US Agency for International Development (USAID) and the World Health Organization (WHO), WFP, the German Provincial Reconstruction Team (PRT) in Badakhshan, the International Organization for Migration (IOM), as well as NAC's own contingency contribution.

The NAC thanks all its contributors that have supported the organization throughout the year – donors as well as all individuals in both Afghanistan and Norway that have made its work worthwhile.

### Funding in USD

DONOR	2006	2005
NORWEGIAN MFA	753,400	738,783
NORAD	695,806	966,506
FOKUS	141,177	180,779
<b>Total Norwegian funding</b>	<b>1590,383</b>	<b>1886,608</b>
USAID REACH	380,402	853,638
USAID through WHO	597,515	-
WHO project income reinvested	5,523	-
<b>Total USAID/WHO</b>	<b>983,440</b>	<b>853,638</b>
GERMAN PRT, Badakhshan	115,911	281,395
IOM	79,427	521,749
NAC for contingency use	4,583	-
JAPAN	-	6,853
FRIENDSHIP	-	210
<b>Total other</b>	<b>199,921</b>	<b>810,297</b>
<b>Sub-total</b>	<b>2,773,745</b>	<b>3,554,170</b>

In addition, the WFP donated 400.93 MT of food stuffs in kind.

**Expenditure by Sector in USD**

<b>SECTOR</b>	<b>2006</b>	<b>2005</b>
HEALTH	1,102.535	1,270.452
ENVIRONMENT	239.572	550.478
CONSTRUCTION	584.131	940.666
EDUCATION	387.699	344.969
ADMINISTRATION	262.365	432.418
VOCATIONAL TRAINING	151.225	-
VARIOUS OTHER	29.869	15.187
GENDER	16.349	-
<b>TOTAL</b>	<b>2,773.745</b>	<b>3,554.170</b>

**Expenditure by Geographical Area in USD**

<b>Geographical Area</b>	<b>2006</b>	<b>2005</b>
GAZNI	1,428,373	1,763,310
BADAKHSHAN	959,698	1,498,971
KABUL	170,003	35,309
<b>JALALABAD</b>	<b>133,373</b>	<b>180,779</b>
PESHAWAR, PAKISTAN	82,298	75,801
<b>TOTAL</b>	<b>2,773,745</b>	<b>3,554,170</b>

Donor wise contribution

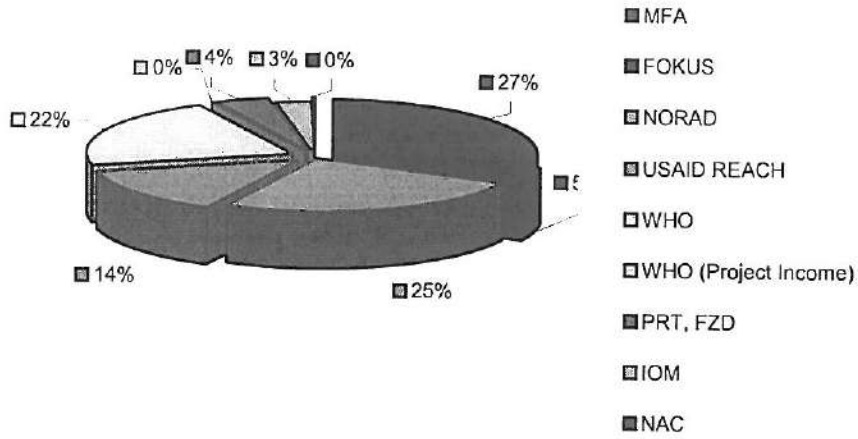

Expenses sector wise

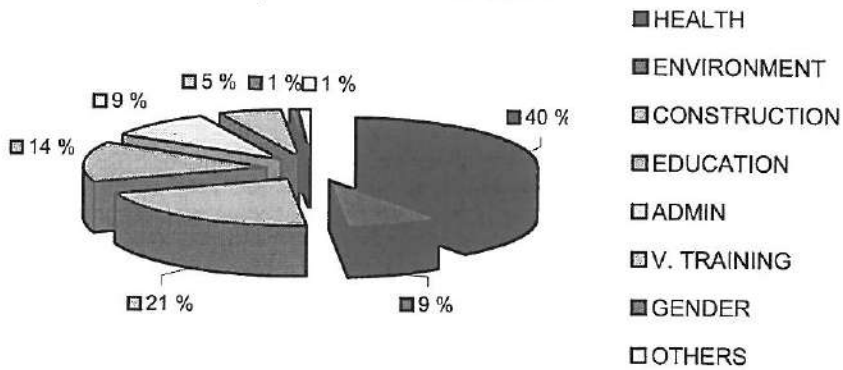

### Expenditure area wise

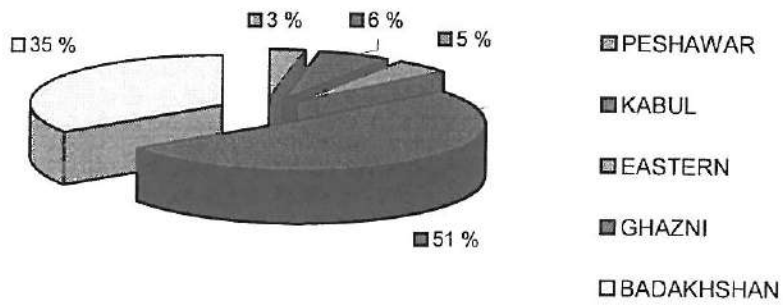

## Organizational Structure and Administration

NAC Norway Office. The NAC Board comprises on average 10 members, of which 1 is of Afghan origin. Working out of a small office, a Secretary General has been employed on a full-time basis, supported by either a Trainee, Assistant, or Information Officer throughout most of the year. A Financial/Accounting Consultant was hired on a needs basis.

NAC Afghanistan Office. In Afghanistan, NAC's Central Office is located in Kabul. The Central Office supports NAC's two Regional Offices in Ghazni city and Faizabad, the respective capitals of Ghazni and Badakhshan provinces. In Badakhshan, the NAC also runs a sub-office in Keshem town. The Regional Offices are run by a Program Office Managers, while each Regional Sector is headed by a sector specialist. A Finance and Administration Sector supports the Regional Offices' operations. The NAC maintains one staff house in respectively Kabul, Ghazni city, Faizabad and Keshem in order to provide accommodation to its staff based on a specific needs criteria.

Staffing. As of 2005, the entire permanent NAC staff in Afghanistan were Afghan nationals. At the end of 2006, a temporary foreign Program Advisor was hired in order to provide complementary support to the organization.

Two new Vocational Training Centers, respectively in Ghazni and Badakhshan, were set up and equipped. Twelve new staff were recruited to run these centers.

Office Location	Permanent staff		Project staff	
	2005	2006	2005	2006
Kabul	24	30	6	
Badakhshan	29	31	37	31
Ghazni	31	31	269	286
Jalalabad	4			41
Peshawar			77	79
<b>Total</b>	<b>88</b>	<b>92</b>	<b>389</b>	<b>437</b>

Audits and evaluations: An audit of accounts for all NAC activities is carried out at least once a year. Financial and program evaluations are also performed regularly upon donor request.

The NAC is registered as an NGO with the authorities in both Norway and Afghanistan.

## NAC Board and Senior Staff

### Contact Information for 2007

#### Interim Board as of 23<sup>rd</sup> March 2007

<b>Chair</b>	Cecilie Nordfeldt
<b>Vice Chair</b>	Linda Våge
<b>Member</b>	Thomas Frantsovold
<b>Member</b>	Carl Hofslie
<b>Member</b>	Helge Liland
<b>Member</b>	Noor Sabah Nael
<b>Member</b>	Christer Nexmark
<b>Member</b>	Kari Solaas Paulsen
<b>Member</b>	Sandra Petersen
<b>Member</b>	Solveig Sandalsnes
<b>Supplement member</b>	Gudmund Moren
<b>Supplement member</b>	Kjetil Bøe
<b>Supplement member</b>	Britt Kejo

#### Control Committee Head

Jorge Dahl

#### Oslo Office

**Secretary General**      Liv Kjølseth

#### Address and Contact

The Norwegian Afghanistan Committee (NAC)

Osterhausgaten 27

0183 Oslo, Norway

Phone No : +47 - 22 98 93 15

Fax : +47 - 22 98 93 01

E-mail : [ain@afghanistan.no](mailto:ain@afghanistan.no)